

# Door Handing & Installation Manual for Series A500 2" Backset Mortise Lock Cases

## **CAUTION!! DO NOT OPEN THE CASE CAP ALWAYS WEAR EYE PROTECTION**

- The Mortise Lock Case is a precision mechanical product, constructed with a number of moving parts and springs. It requires a special jig and technique to assemble. Opening the case cap without using a proper jig and or tool may result in serious personal injury by flying parts and springs.
- **Removing the case cap to change the handing is not necessary.** Please read the following carefully before changing the handing and installing the Mortise Lock Case.

### **Step 1 -**

Remove the Faceplate Screws and the outer Faceplate

### **Step 2 -**

Depress the Latch Bolt and remove the Latch Screw

### **Step 3 -**

Pull the Latch Bolt, rotate 180 degrees, and then snap the Latch Bolt back to its working position in slot. Fasten the Latch Screw. For a Passage Function lock and or any other function locks that uses a H/L or H/K trim set, go to Step 5.

### **Step 4 -**

Depress the Release Button. Remove the Stop Button Screw and the Block. Place the Block to the Stop Button Slot on the reverse side of the lock case and fasten with the Stop Button Screw.

### **Step 5 -**

Adjust the proper angle of the Armor Front to fit the Beveled or Flat edge door, and fasten the Armor Front adjustment Screws. The Armor Front of the lock is designed for a maximum of 2.5 degrees rotation (or a maximum 1/8" beveled cut for a 2" thick x 4' wide door), left or right, bevel adjustments. Any greater angle may cause lock jam or malfunction.

### **Step 6 -**

Install the lock case on to the door, fasten with Mounting Screws.

### **Step 7 -**

Install the Trim Set\*\* (See Installation Instruction For Trim Set)

### **Step 8 -**

Install the Mortise Cylinder\*\*, if applicable. The Mortise Lock Case takes any standard Mortise Cylinder (1.15" -32NS) that is formed with a 'C1' type cam only. Proper length of the cylinder is required to ensure the smooth operation. Cylinder length can be determined by calculating 1/2 door thickness plus the projection height of the Trim or the Security Collar for the cylinder. If you use a single cylinder only, the Cylinder Plug must be installed on to the other side of the Cylinder Slot, prior to fastening the Cylinder Yoke Screw. You may use a spindle to screw the Cylinder Plug into the slot. Make sure one of the notches is lined up, to engage the Cylinder Yoke, as well as the cylinder.

### **Step 9 -**

Attach the Faceplate and fasten with the Faceplate Screws.

**Test the lock function before CLOSING DOOR.**

Save this manual for future reference.

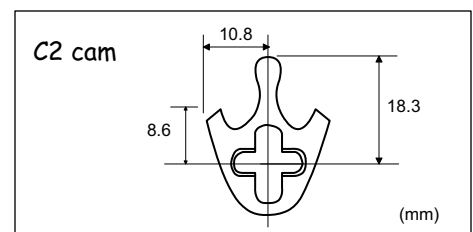
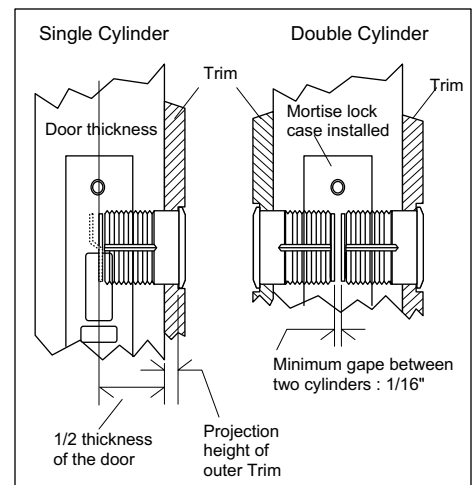
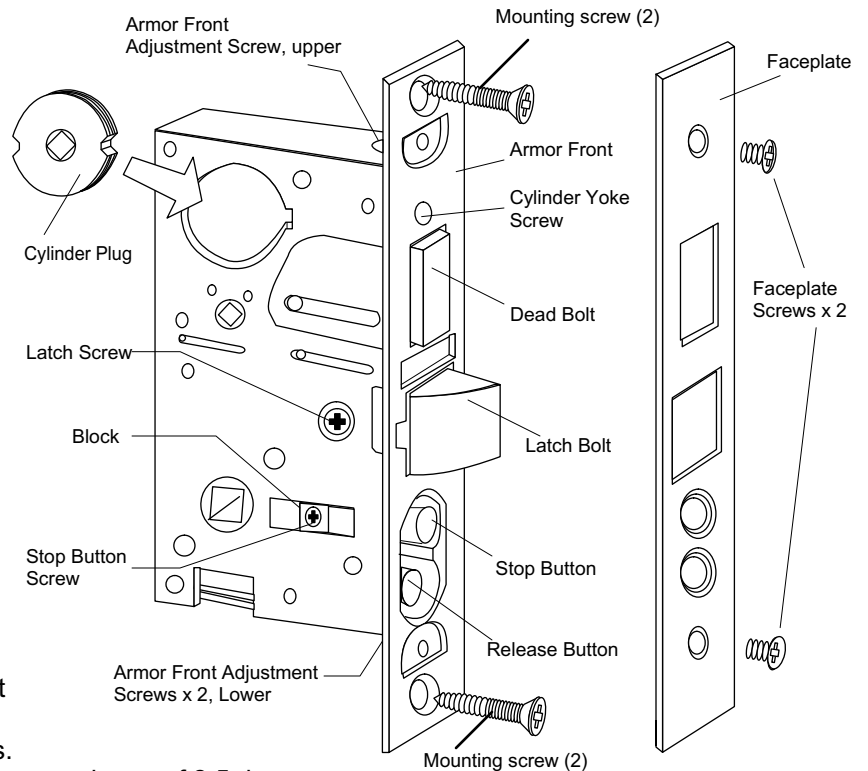

\*\*\*: Trim set and Cylinder are separate purchase items.